

Assembly Instruction ✓

Fritz Series







Welcome Guide

www.sohnne.com

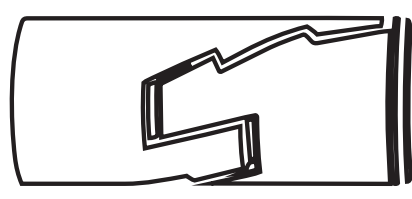
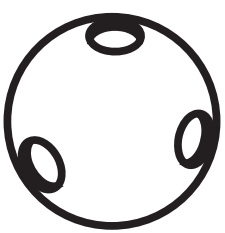
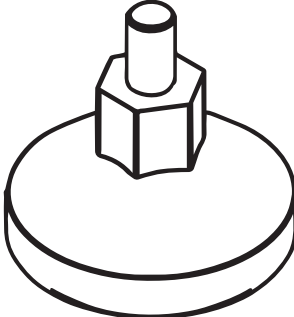
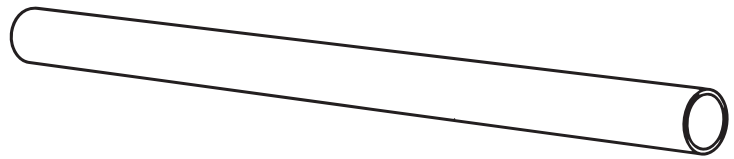
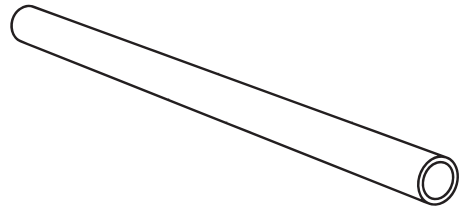
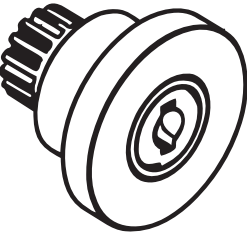
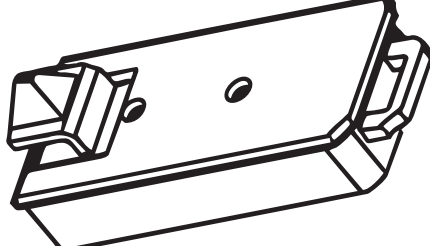
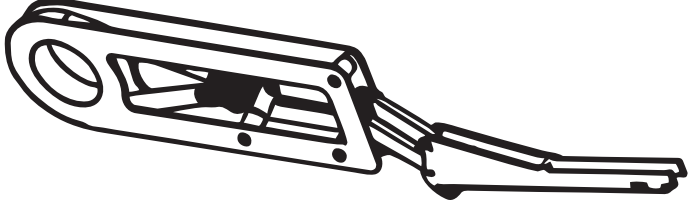
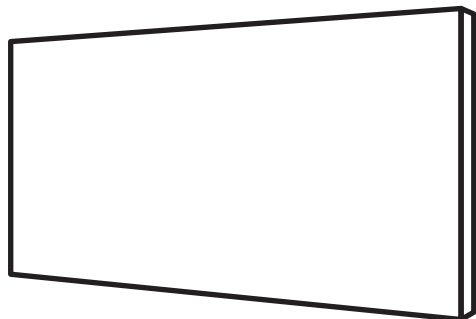
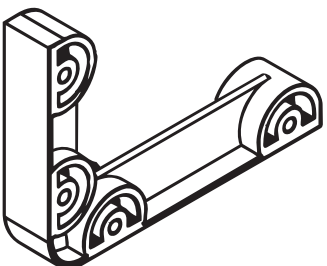
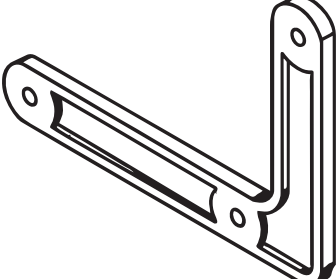
Assembly Instruction

Please follow the instructions below for correct assembly

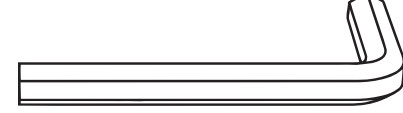
<p>Ⓐ</p>  <p>Cylindrical Threaded Connector</p>	<p>Ⓑ</p>  <p>Sphere Joint</p>	<p>Ⓓ</p>  <p>Feet</p>	<p>Ⓔ</p>  <p>Long Rod</p>
<p>Ⓕ</p>  <p>Short Rod</p>	<p>Ⓖ</p>  <p>Door Knob</p>	<p>Ⓗ</p>  <p>Door Lock Housing</p>	<p>Ⓖ</p>  <p>Door Hinges</p>
<p>Ⓘ</p>  <p>Steel Panels</p>	<p>Ⓙ</p>  <p>Hinge Bracket</p>	<p>Ⓚ</p>  <p>L Shaped Mounting Bracket</p>	<p>Ⓛ</p>  <p>Hinge Pin / Rivet</p>
<p>①</p>  <p>M4x25</p>	<p>②</p>  <p>M3x25</p>	<p>③</p>  <p>M4x13</p>	<p>④</p>  <p>Allen Key</p>

STEP 1

Insert the cylindrical connector (A) into each sphere joint (B) at the appropriate port. Use the allen key (4) to tighten the cylindrical connector.

But do NOT fully tighten at this step. Keep all joints loose to allow adjustment once the full structure is assembled.

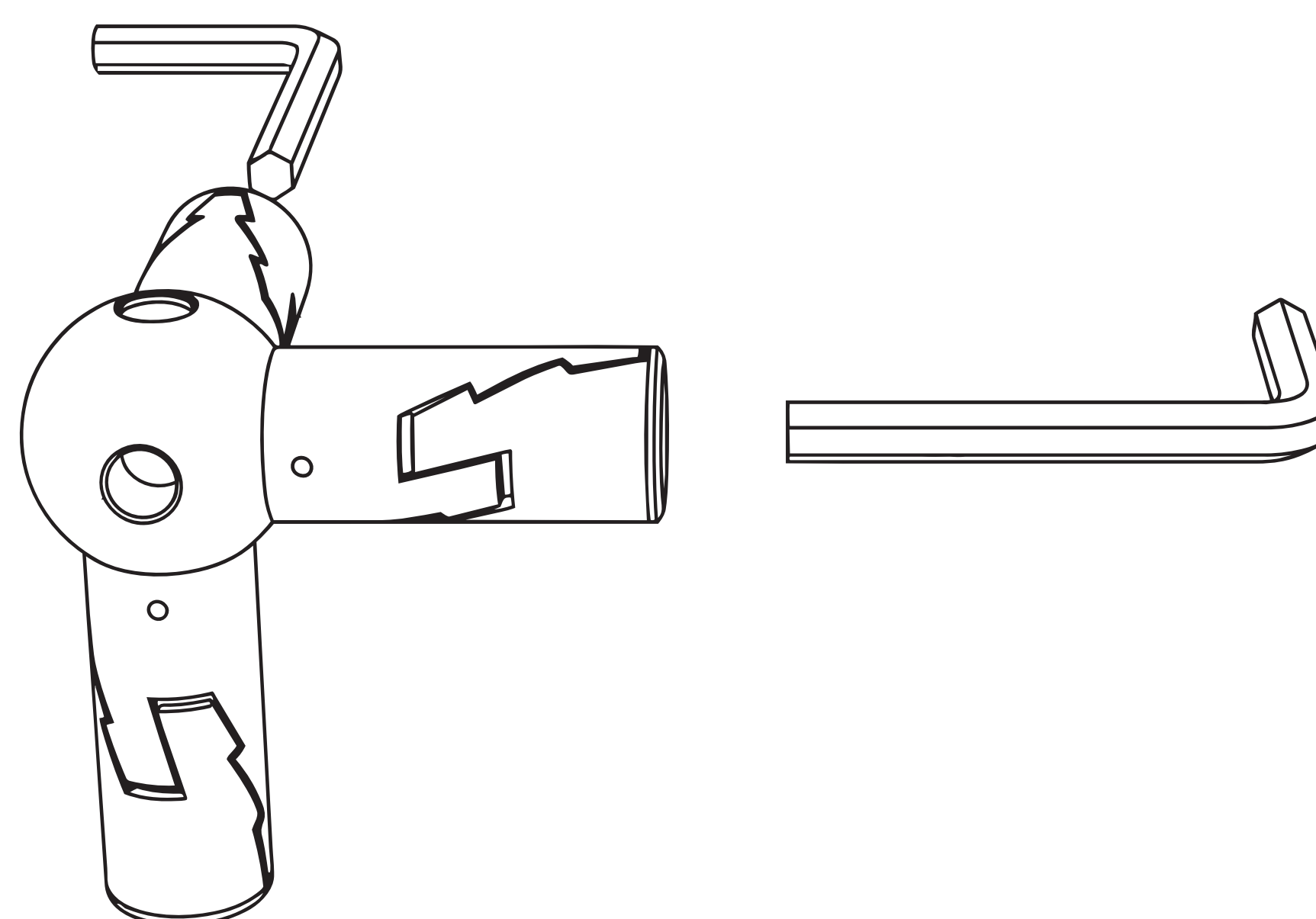

STEP 2

Insert short rod (F) between two sphere joints at both ends. Use allen key one at each end to sea the rod.

Ensure a seamess connection

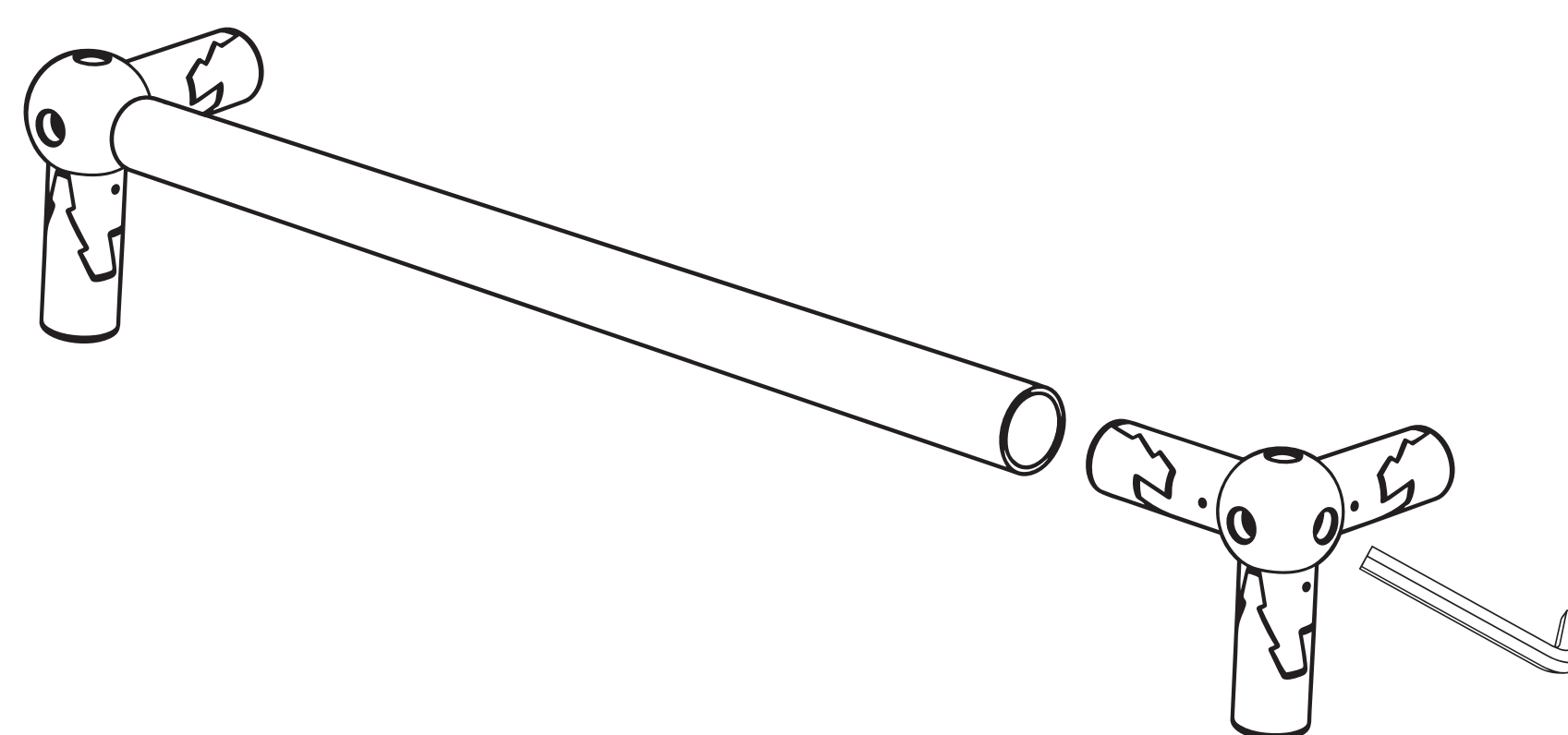

STEP 3

Connect the long rods (E) to the sphere joints to extend the frame outward. Use the T-handle for better torque.

Continue until the frame closes into a complete rectangle. Keep all joints loose.

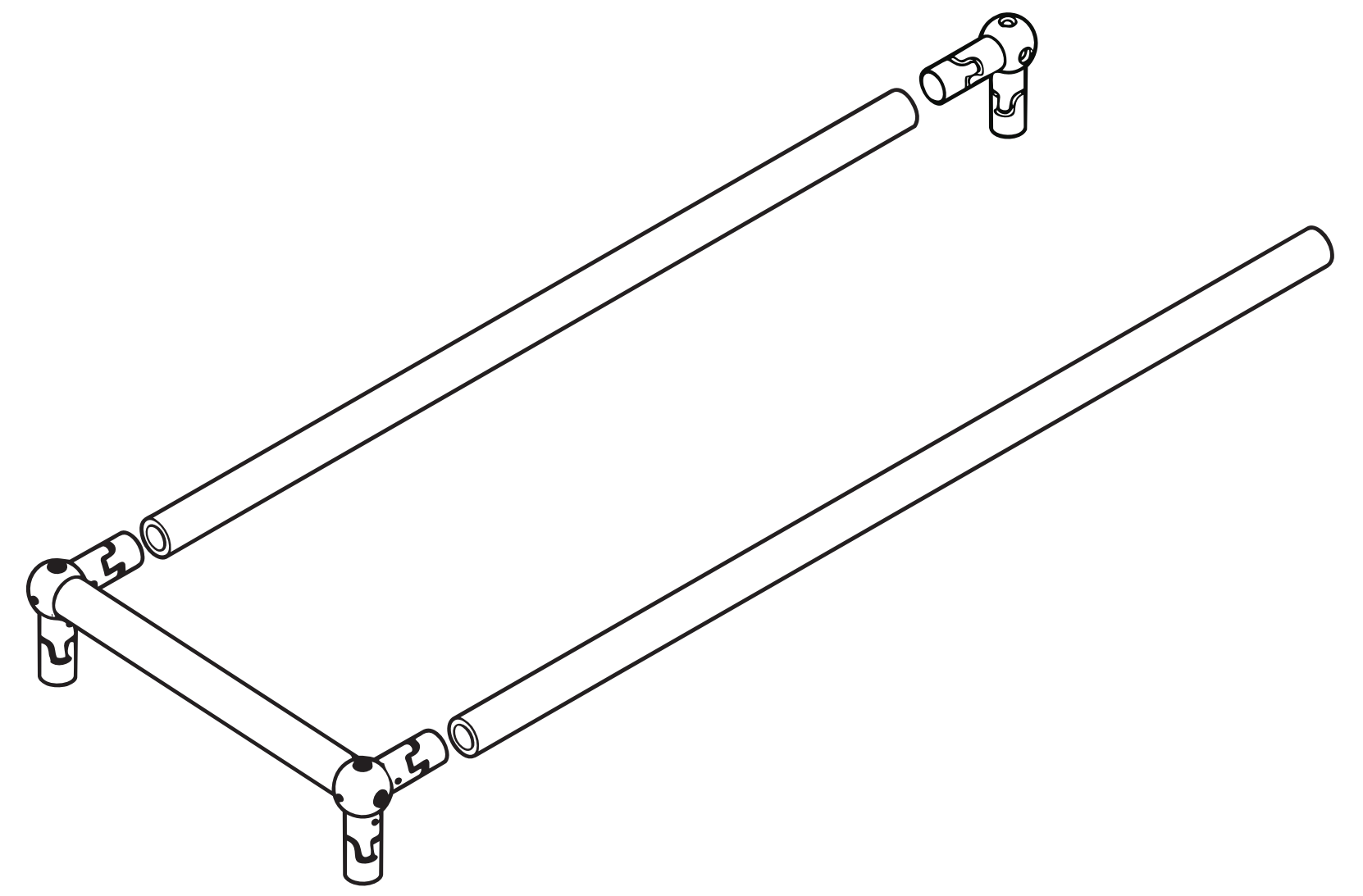

STEP 4

Screw the feet (D) into the bottom sphere joints.

Each foot has a flat rubber base and a threaded bolt stem.

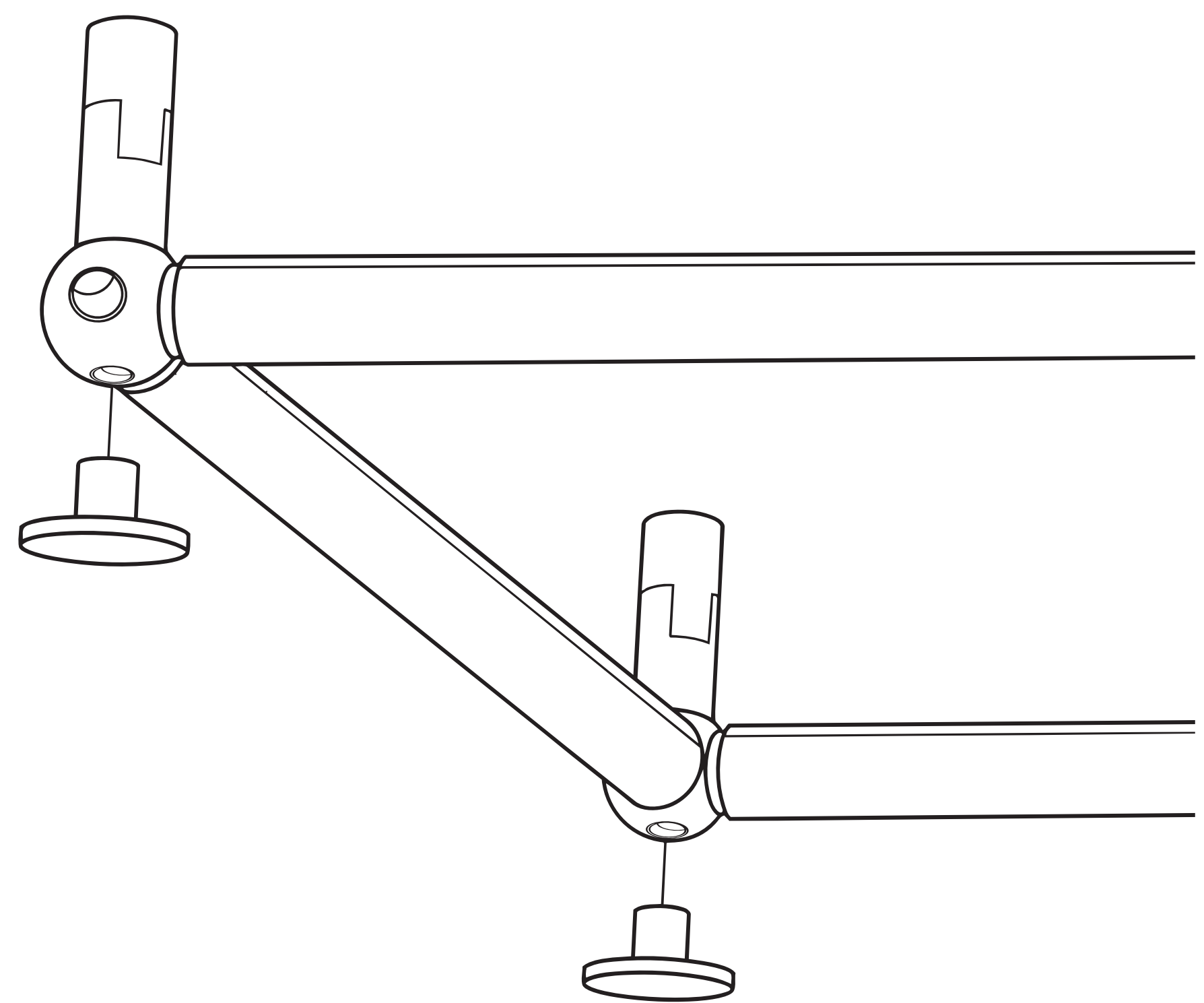

STEP 5

Attach hinge parts to side panels. Position L-brackets (K) at the panel corners and insert hinge pins (L) through the hinge brackets (J). Clamp the door hinges (H) around the vertical rod. Secure with M4x25 screws (1) in a cross pattern to avoid warping.

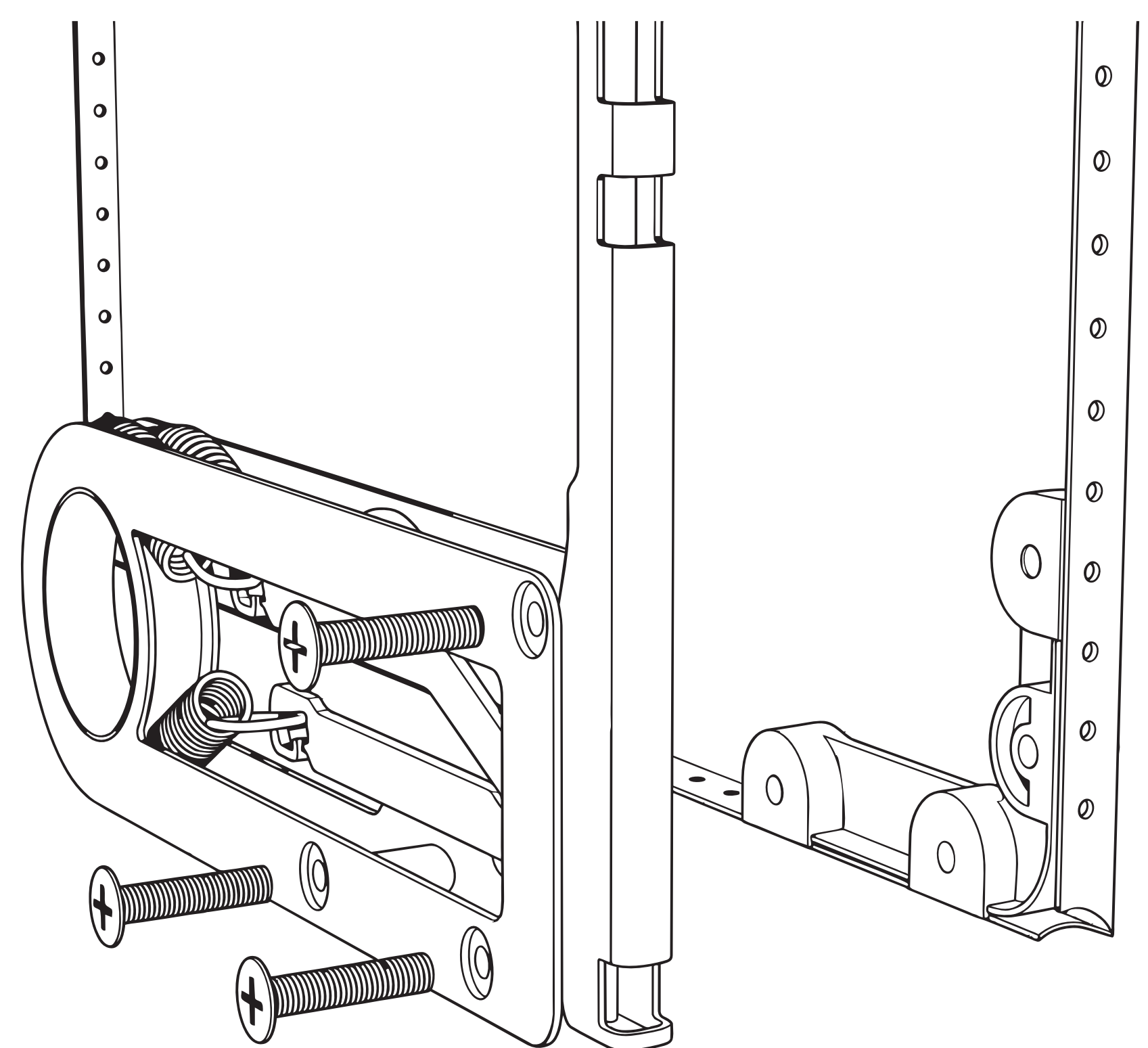

STEP 6

Insert the all panels into the frame, pivoting them into position using the hinges. Close both panels fully flush with the frame.

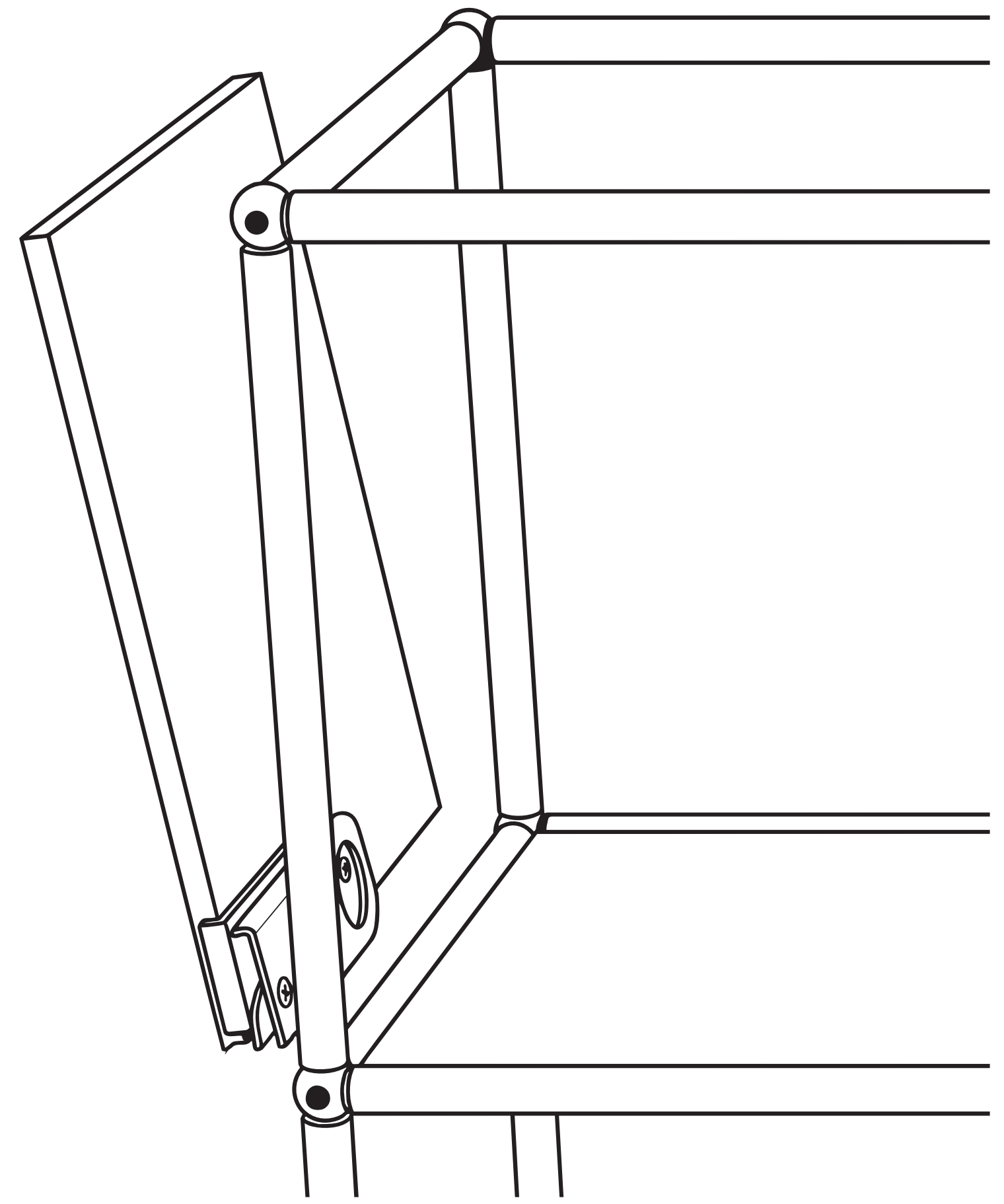

STEP 7

Assemble the lock: insert the spring-loaded clamp into rectangular door lock housing (H). The clamp grips the horizontal rod when the door is closed. Clip the assembled lock unit onto the top center edge of each door panel.

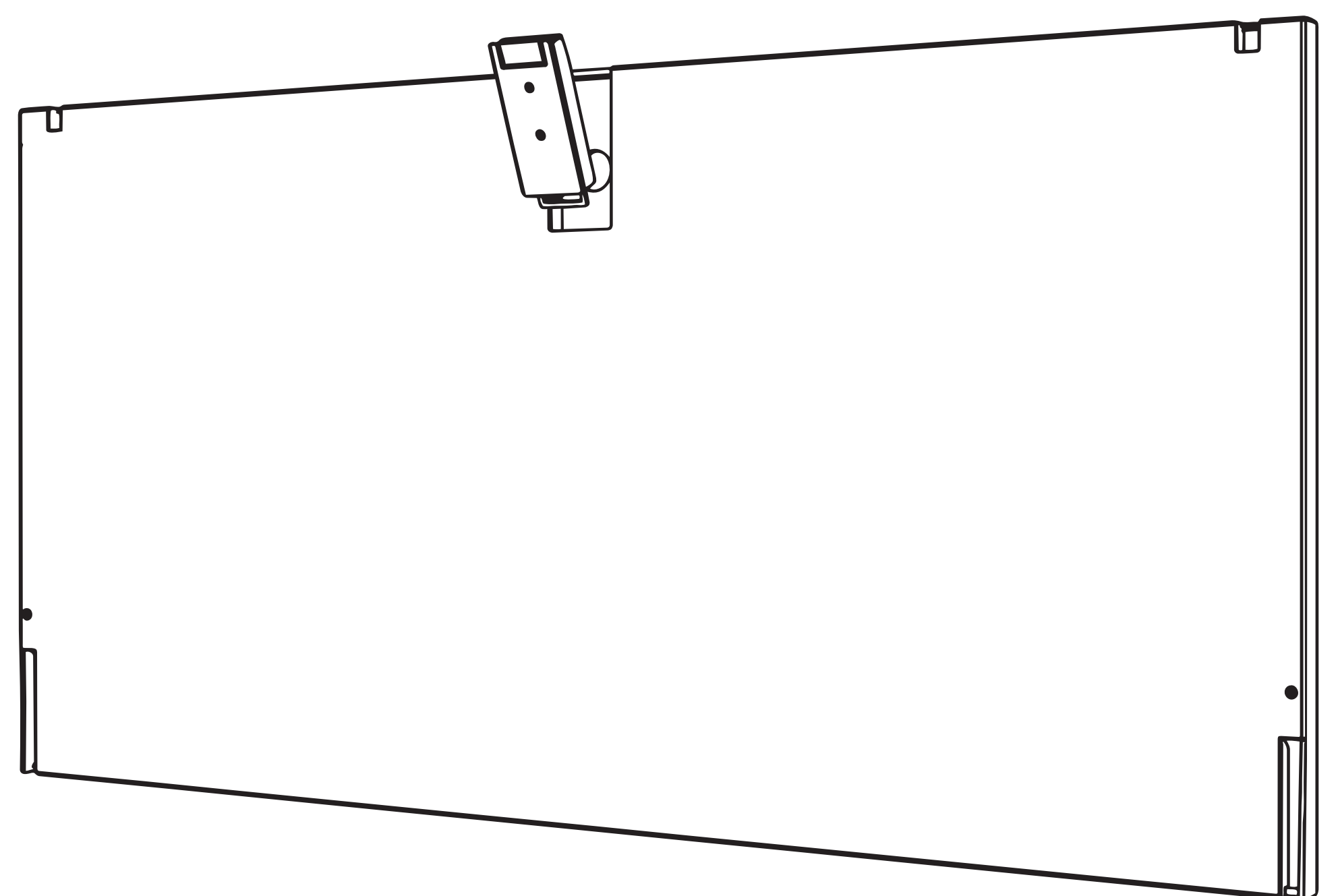
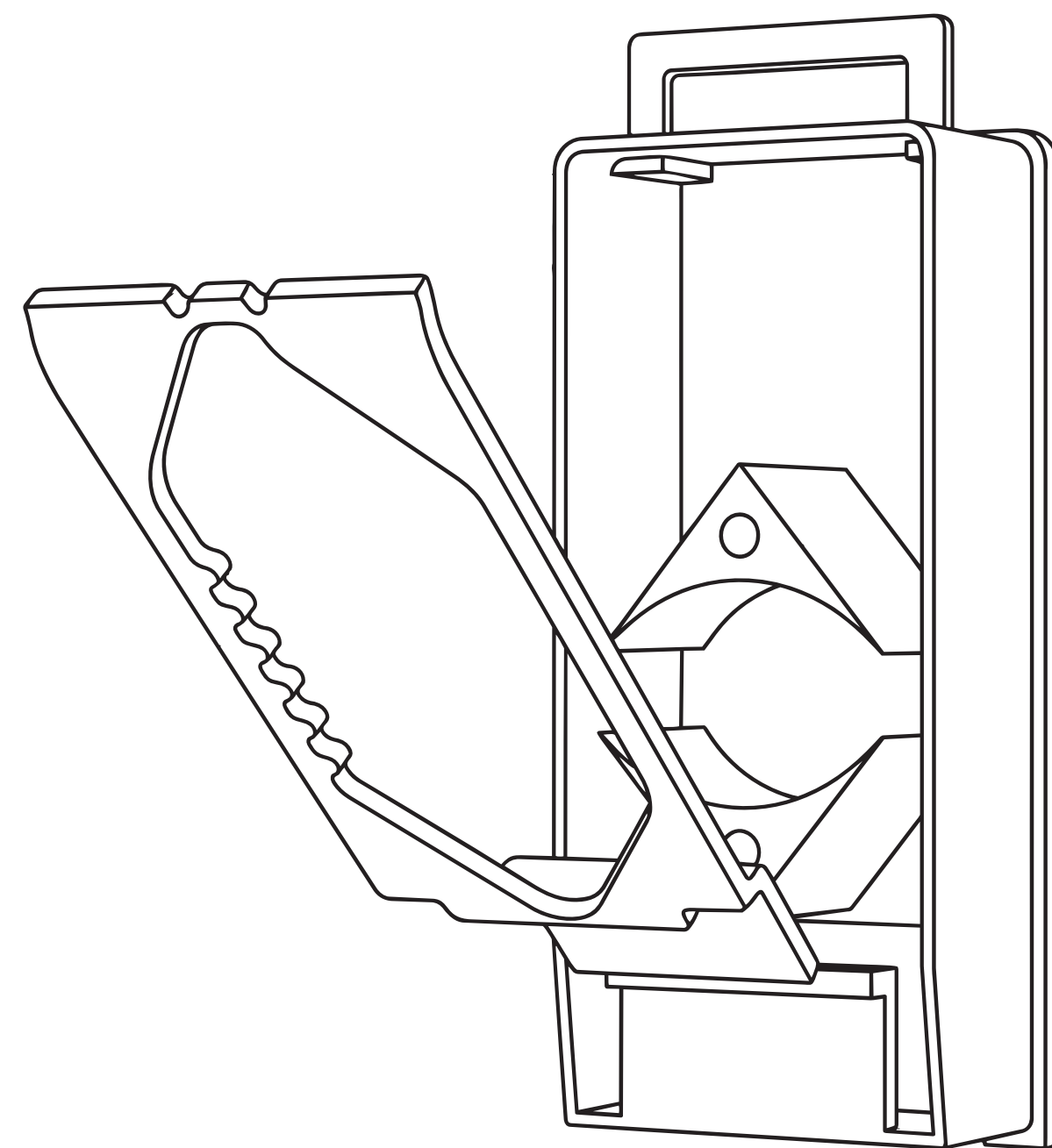

STEP 8

Insert the door knob (G) through the pre-drilled hole on the front face of door panel. The knob has a flat-head slot for tightening with a screwdriver. Turning the knob engages or disengages the spring latch.

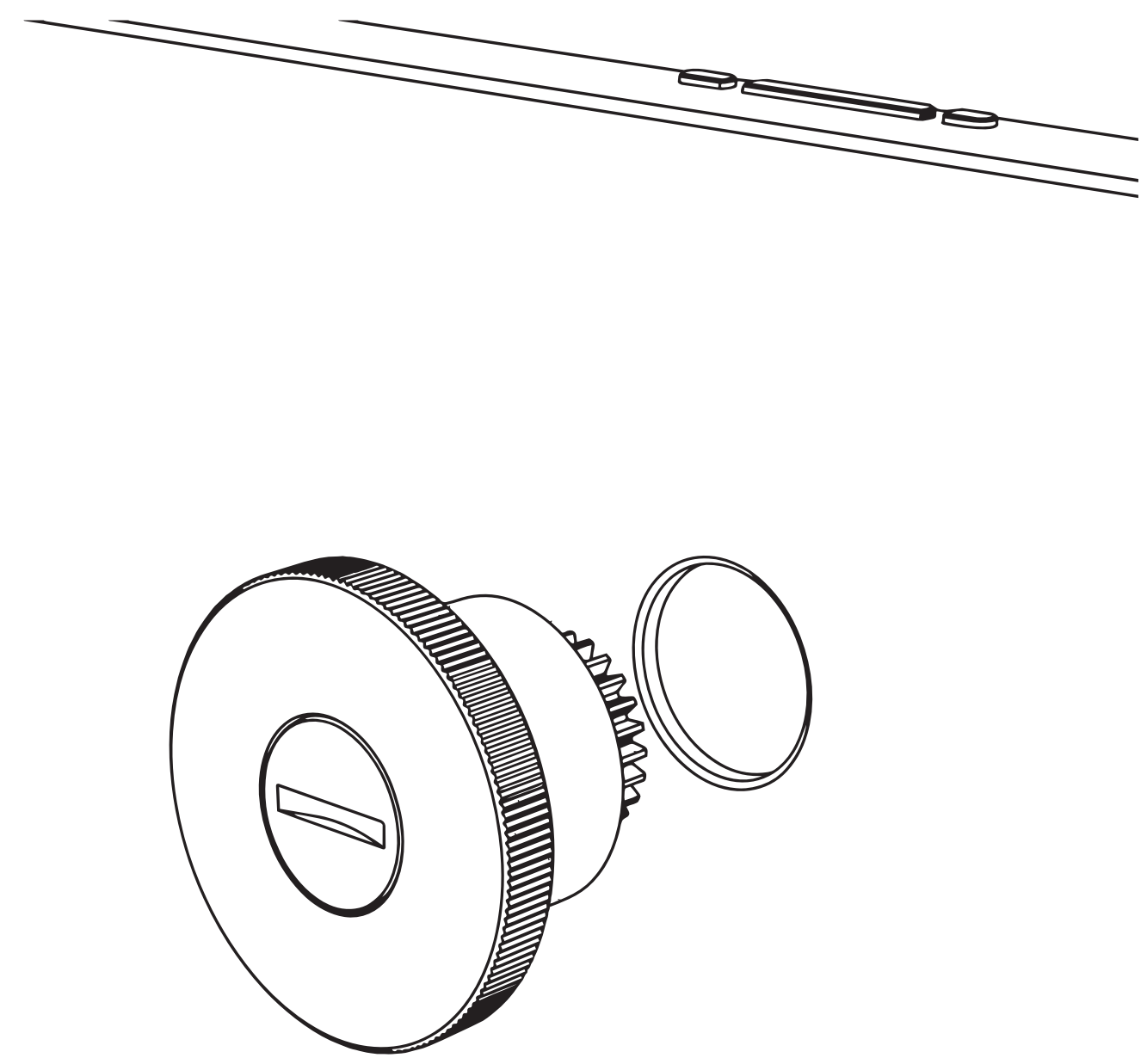

STEP 9

From the back of the door panel, secure the black lock housing permanently using M3x25 screws (2).

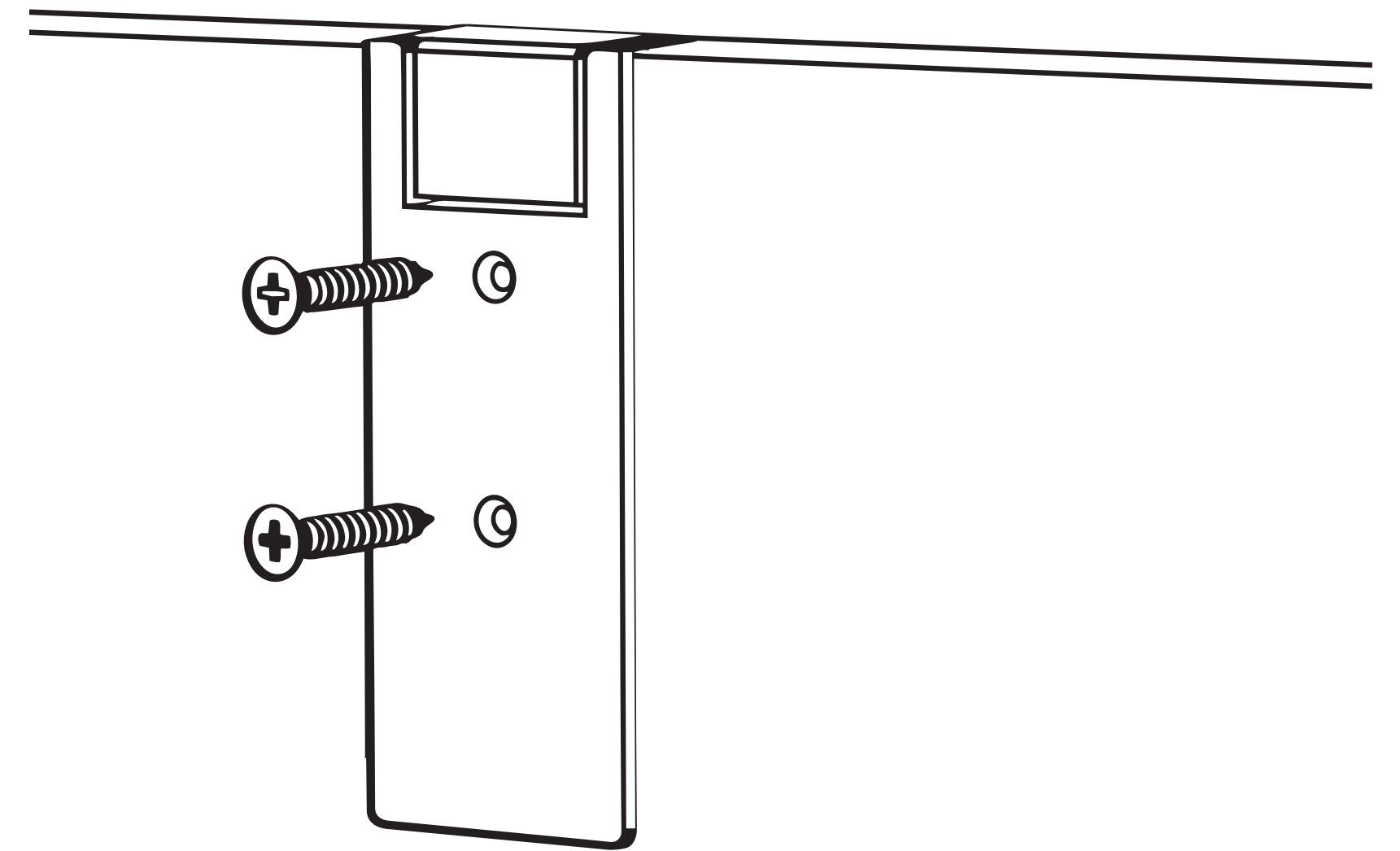

STEP 9

From the back of the door panel, secure the black lock housing permanently using M3x25 screws (2). Check the doors are at the same height. Doors should swing freely and close flush with the frame with an audible lock.

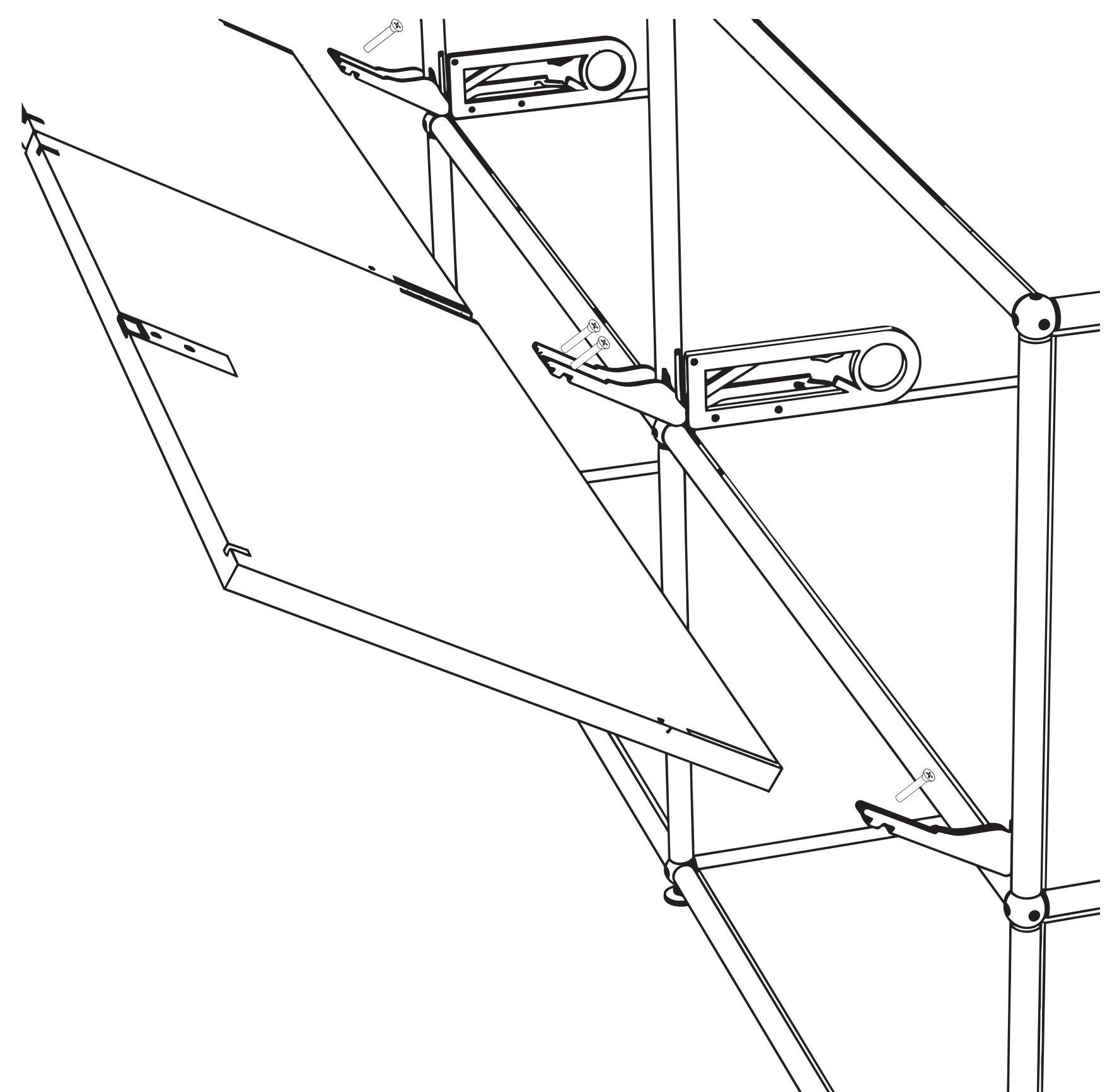

CARE INSTRUCTION

With regular maintenance and inspection, your Lounge Chair and Ottoman will provide many years of superior performance and satisfaction.

Leather Cushions: Using a soft cloth, wash periodically with lukewarm water and a mild soap (Ivory[®] or Castile Bar Soap). Wipe with another clean, damp cloth. Buff dry with a soft cotton towel.

Wood Veneer Panels: Furniture polish, free of solvents or abrasives, applied with a soft cloth following all application instructions. Suggested Cleaners: Guardsman Anytime Clean and Polish Pledge Lemon Enhancing Polish.

Polished Aluminum Base & Back Support Surfaces: Polish with Johnson's[®] Wood Floor Paste Wax according to the manufacturer's instructions.

General Cleaning Guidelines: Avoid using abrasive cleaners on the polished steel or painted parts of the chair or ottoman. Painted metal surfaces should be cleaned with a soft cloth and mild soap, carefully rinsed and then buffed dry

NEED MORE INFORMATION?

We hope that user guide has given you the assistance needed for a simple set-up. For the most up-to-date guide for your product, as well as any additional assistance you may require, head online to:

 +1 (833) 900-0017

 support@sohne.com

 www.sohne.com

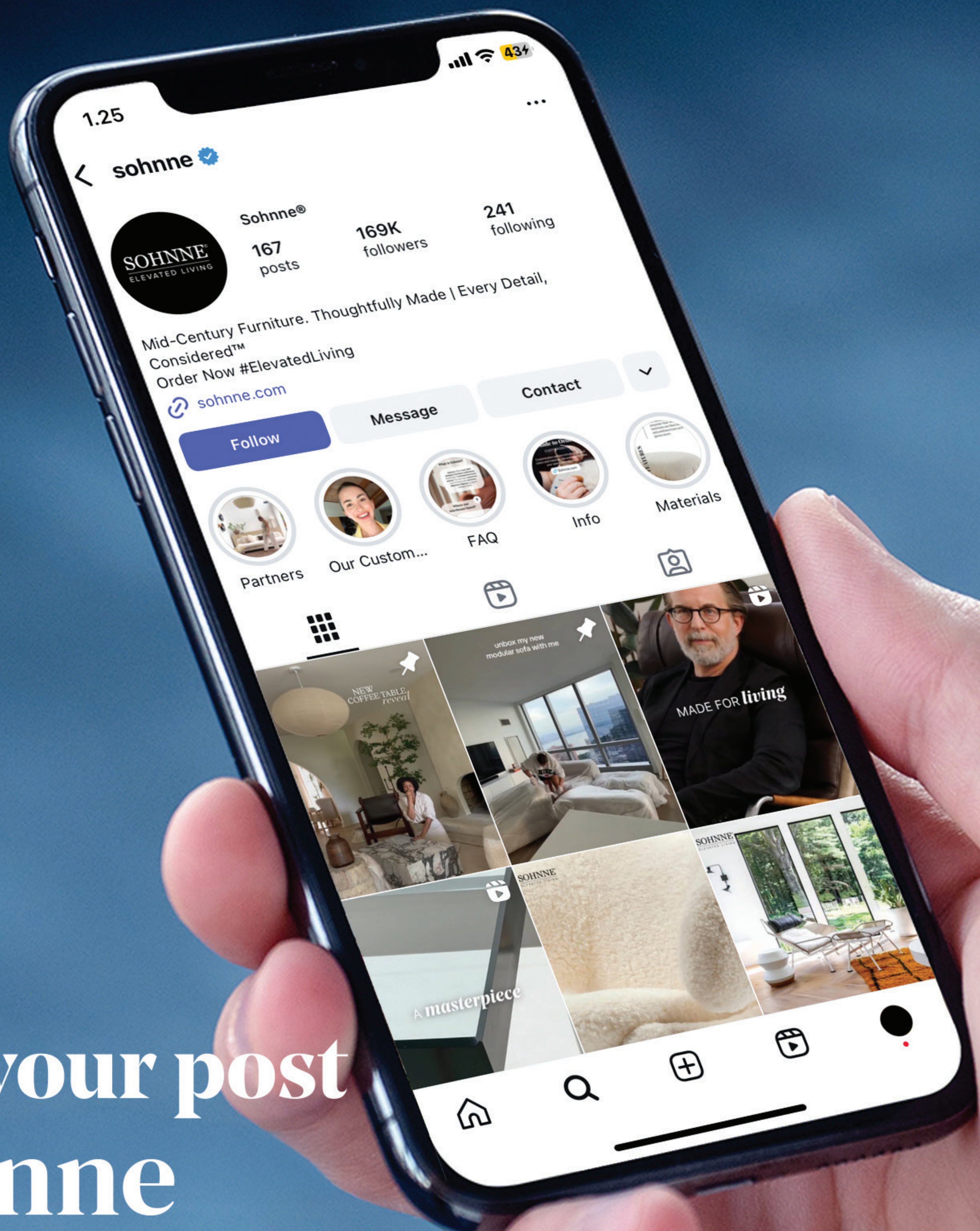

Tag in your post @sohnne



\$50 off for photo review



\$100 off for video review

SOHNNE[®]
ELEVATED LIVING